



Community Support Division
1700 North 116th Street
Phone (414) 471-8430
Fax (414) 471-8470

Wauwatosa Police Department

BURGLARY PREVENTION TIPS

One of the most personally devastating crimes can be a burglary because of the invasion into what we all feel is our safe haven. Provided below are tips that will help make your home or business more burglary resistant.

- Leave exterior lighting on around your home during all hours of darkness.
 - Low level outdoor lighting fixtures should be left on from dusk to dawn. Using compact fluorescent bulbs in outdoor fixtures is not only energy efficient but it also provides great facial and color recognition without being a nuisance to your neighbors.
- Another option is low level motion detectors that are properly aimed and adjusted. Aiming and adjusting is important so it does not shine in neighbor's windows or come on more often than really needed.

Lamp Attributes

LAMP	COLOR	HOURS	WATTAGE	EFFICIENCY
Halogen	Crisp White	1,500	15-500	Least
High Press. Sodium	Yellow Tint	10,000	35-70	Better
Compact Fluorescent	Warm White	10,000	13-26	Better Yet
LED	Bright White	40,000	20-60	Best

Lighting Diagram

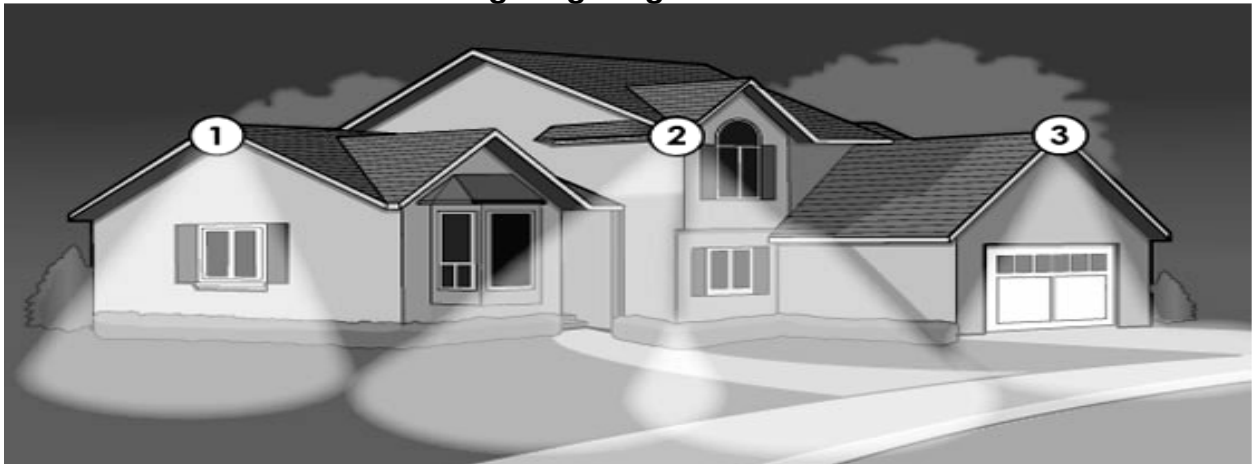

**Apply the same principal to all sides of your home, business and all out buildings.
Please be cognizant of light pollution to your neighbors.**

- Lock all doors and windows when not at home or while sleeping.
 - For windows of all types, consider installing after market keyed window sash locks.

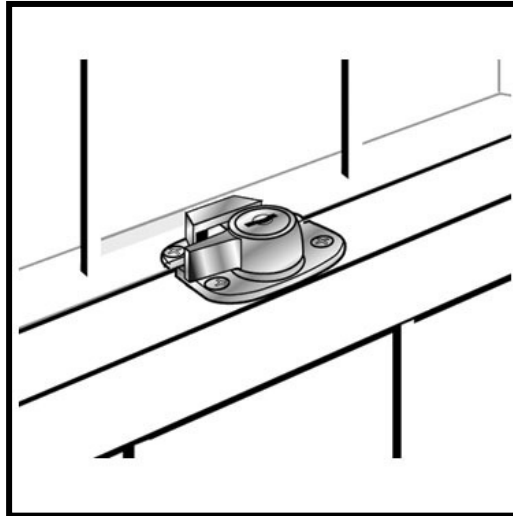

One example of a keyed window sash lock

- Double hung and sliding windows should be pinned so that they cannot be open more than 4". Pinning is accomplished by drilling holes into both frames of a double hung window that you can place some sort of pin through both frames in the closed position as well as while open.
 - By pinning the windows at 4" you receive ventilation while preventing anyone from reaching in or entering your property without physically breaking the glass. If you are installing new windows, purchase windows that have pinning devices built in.

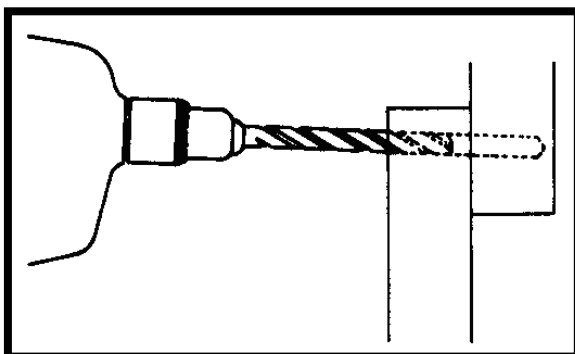

Drill through both the upper and lower frames in both the closed position and with the window open to a maximum height of 4" on both corners of the window

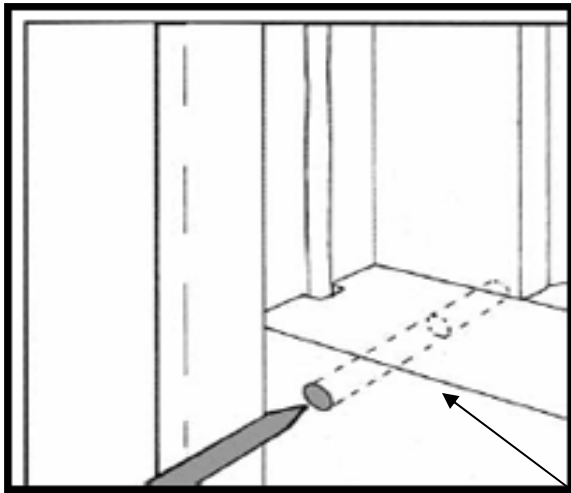

Insert your pinning device through both frames

A duplex nail or eyebolt can be used as your pinning device

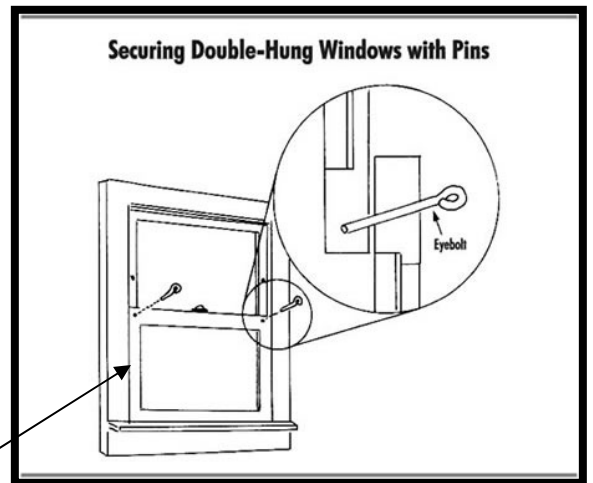

Both corners pinned, shows the holes in upper frame to be used when pinned open.

- Never keep purses, laptops, briefcases, wallets or other items of value on tables or counters near windows.
- Basement windows that are not glass block should have horizontal security bars placed across the middle of the glass and mounted on both sides with appropriate mounting hardware. You may consider having a few that are hinged on one end and locked or latched on the other for an escape route.
 - Please refer to fire codes if your basement is being used as living space because then you will be required to have an escape window or door.

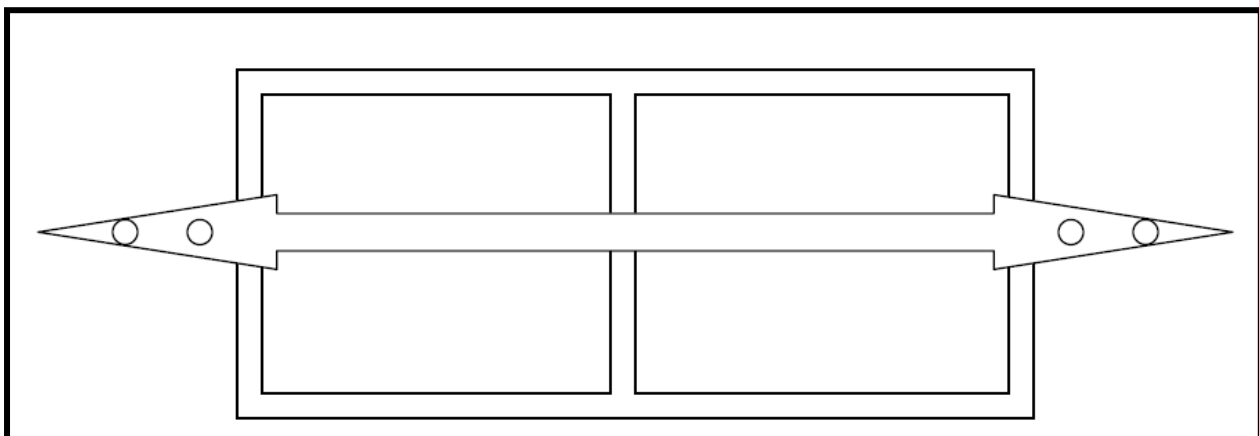

A horizontal security bar placed across a single pane basement window with proper masonry mounting bolts/screws at least 3" long.

- Make sure all exterior doors are solid wood or metal and the hinges are on the inside of the building. If the hinges are on the outside replace them with security hinges that will prevent anyone from removing the hinge pins.
- Replace inferior dead bolts or in the case were no dead bolt exists, install a “Grade 1” or “Grade 2” deadbolt that has at least a 1” throw and beveled housing to resist gripping and twisting.

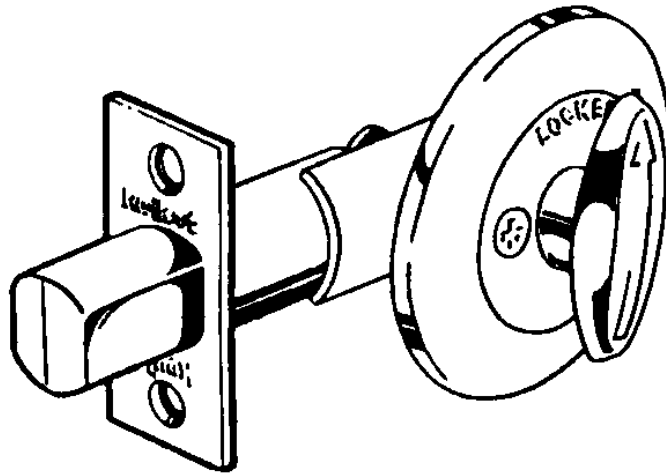

- All lock strike plates (the plate that a dead bolt or door knob bolt goes into, penetrating the door frame) affixed to door frames should be mounted with 3” screws. Consider an after market strike plate that requires 4 screws for mounting.
 - By using longer screws that go deeper into the framing anyone using a foot or ramming device to break the door in at the lock will have greater difficulty in entering in this manner and in most cases will be unable to do so.

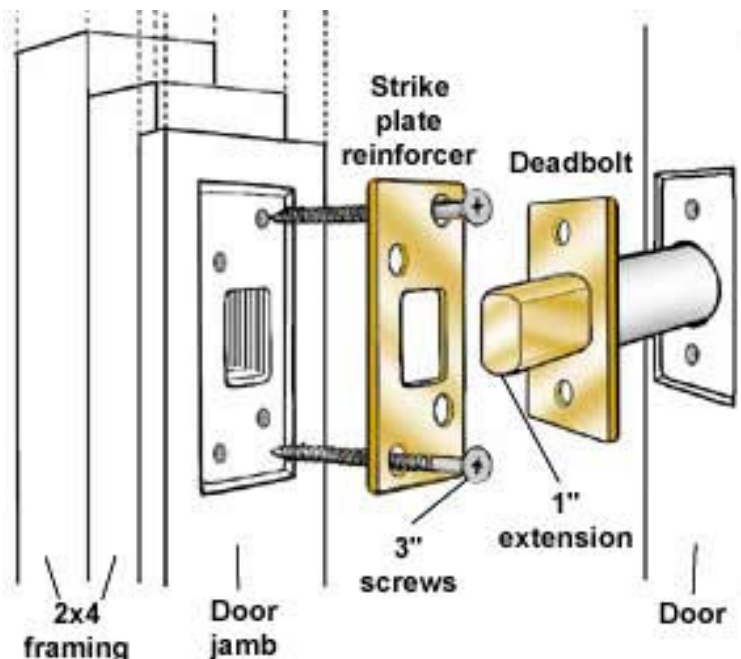

- Consider replacing exterior door knob-in-lock sets with those that have a “dead latch” mechanism to prevent slipping the lock with a shim or credit card. This does not cancel out the need to have a deadbolt on all exterior doors.

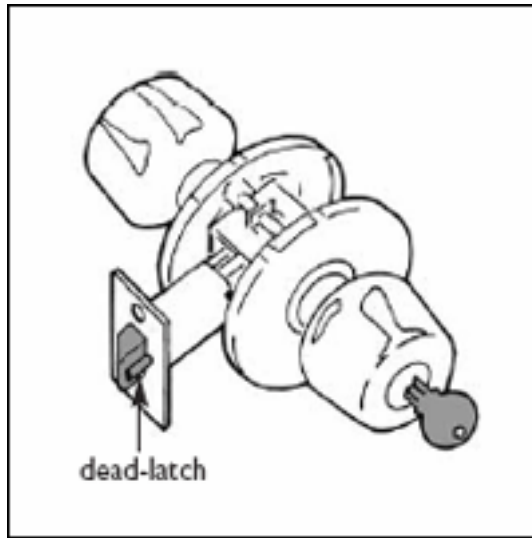

- If you have glass within 40” of the door’s deadbolt consider a security screen mounted over the glass with screws as long as the door or interior wall is thick. Another fix is to have a glazer apply a residential grade security film to the glass.
 - Both of these modifications will make it more difficult for someone to break the glass and reach inside to turn the deadbolt.
- In doors without a window consider installing a wide-angle 160° peephole mounted no higher than 58 inches. For those homes with children consider mounting a second one at a lower height; also reinforce to your children to never unlock and/or open the door for strangers.
- For homes with sliding glass doors consider pinning the doors at the top and bottom of the door frames just as you would with a double hung window.
 - A piece of wood cut to fit in the lower channel of the track is useful
 - Along with the other options discussed you may want to install a “Charley Bar”,
 - You can also pin the sliding door much like a double hung or sliding window by pinning the top and bottom of the slider.

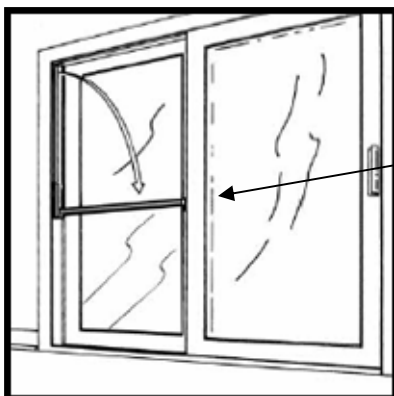

Commercially produced “Charley bar” adds security to sliding glass doors and sliding windows.

- Ensure that all landscaping is trimmed to a height that does not provide a hiding place for would be thieves. Tree limbs should be trimmed back at least 6' from the roof so that no one can gain access to your roof or second floor by climbing a tree.
- Consider planting thorny plants or bushes around your house to deter unwanted people from approaching your homes windows.
- Landscape lighting is a great supplement to exterior lighting and can add to the curb appeal of your home. But please do not substitute landscape lighting for good exterior lighting.
- When installing window air conditioning units most units have holes to run screws through the housing and into the window frame. These holes are accessible by removing the front grill; as is the case with strike plates use 3" screws for mounting.
 - If your air conditioner came with any brackets or mounts make sure you use those as well. You may also consider after market mounting brackets.

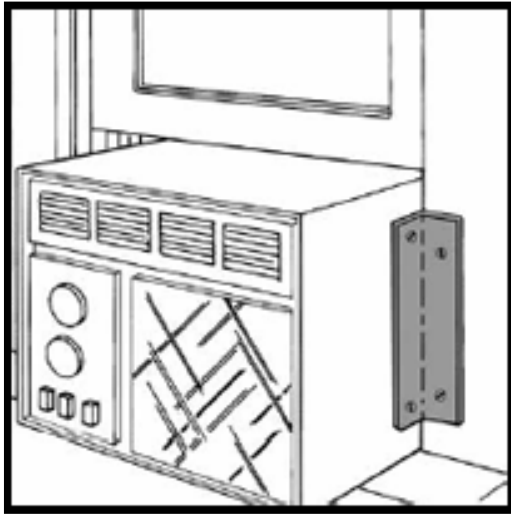

◀ **Window A/C with after market mounting brackets**

- If the air conditioner is smaller than your window opening consider building a frame to go between the air conditioner and the window opening. Make sure you mount that frame to the window framing and then the air conditioner to the frame you built.
- When mounting the air conditioner make sure that you mount it at an angle so that the condensation from it drains out and onto the ground.
- When new big ticket or highly desirable items are purchased, do not leave the empty boxes at the curb for trash pickup; this only advertises your new "Goodies". Take the boxes to the Recycle Center yourself.
- Close your garage door and garden shed when you cannot continuously monitor them.
- Make sure that ladders and other items that may be used for climbing are secured so that burglars cannot use them to gain access to windows and doors on higher floors.

- While not at home keep talk radio on and put interior lights on timers. This will provide the illusion that someone is in the residence and the lighting will make your arrival inside safer and more welcoming if it is dark when you get home.
- Participate in Operation ID. You can borrow, free of charge, an engraver to etch a unique identification number into your valuables.
 - Using the last four digits of your Social Security Number and the last two digits of your Driver's License is a good way to easily remember and identify your items.
- If you have an active Block Watch display your sign inside your residence, facing the street with the appropriate secondary signs in strategic locations.
- If you do not have a Block Watch or yours has become inactive, contact the Wauwatosa Police Department's Community Support Division to start one up or have a refresher meeting.
- When leaving for an extended period of time consider doing the following:
 - Arrange for snow removal / lawn mowing.
 - Arrange for newspaper / mail to be stopped or picked up.
 - Have a trusted friend or relative check on the home.
 - Silence the ringer on your telephone.
 - Talk radio and interior lights on timers.
 - Close the blinds for rooms where expensive and desirable items are kept.
 - Contact the police department and advise them of the following:
 - Departure and arrival dates.
 - Any vehicles / persons okay to be at the residence.
 - An emergency contact.

If you are a Wauwatosa resident or business owner and wish to have a security survey conducted on your home or business please contact the Wauwatosa Police Department's Community Support Division at 414-471-8430.

In Home Service Calls

When inviting installers, repair technicians, or any other services(s) into your home or apartment there are several things to consider. Although the majority of companies are honest and law abiding, an “In Home” visit can expose you to theft, burglary, or worse. Taking simple precautions and preparing for an in home visit is simple.

Whether your furnace or hot water heater needs service, you are having cable, satellite, or telephone service installed, or you are considering a home repair or improvement, there will be occasions when you invite a stranger into your home or apartment.

Before considering a company, get to know your contractor:

- Use reputable companies that are established in your community.
- Use references from family, friends, and neighbors
- Research companies through the Better Business Bureau
- Use insured companies who conduct background checks on their workers
- Compile a list of companies before the need arises so you make sound decisions

Calling For Service

- When making the appointment ask the name of the employee(s) coming to your home
- Ask the exact time you can expect the employee(s) and if they can call just before arrival
- Get a description of the service vehicle(s)

Prepare Yourself and Your Home

- Hide easy to carry away valuables
- Do not “brag” about or “Show off” valuables or collectables
- Have a family member or friend with you during the visit if you are uneasy being alone

Upon Arrival

- Look for marked company vehicle
- Look for employee uniforms and photo identification
- Keep employee(s) under observation and limit access to unnecessary areas
- Be suspicious of employees who appear more concerned about your belongings than their job

If at anytime during a service visit you become uncomfortable, ask the worker(s) to leave.

Personal Safety

Every activity has a level of risk. There are several ways to approach risk:

- Least amount risk: Do not engage in any activity
- Greatest risk: Engage in risky activities without taking precautions
- Limited risk: Enjoy daily activities while taking sensible precautions

Before Exiting Your Vehicle:

- Always park in the best lit area (look for light poles during the day)
- Consider a “brief drive by” past your destination before parking or getting out
- Look around before you exit your vehicle (use mirrors / headlamps / brake lights)
- Have your keys available and in your hand when walking to your destination
- Have your keys available and in your hand when walking back to your car
- Lock your doors once your in the vehicle
- Keep all valuables out of sight and in the trunk (before you park if you can)
- Exercise extra caution when in parking structures or desolate areas

Public Transportation:

- Have the exact change ready
- Do not flash extra cash
- Sit as close to the driver as possible
- If you feel you are being followed, stop near an open business

In A Building:

- Avoid isolated corridors or hallways (short cuts, smoke breaks, etc.)
- Exercise caution in stairwells and restrooms
- Exercise caution in elevators, stand near the control panel and emergency buttons

On The Street, In Parking Structures, or In Parking Lots:

- Use the middle of the sidewalk; walk facing oncoming vehicle traffic
- Do not overload yourself with packages or other items
- Do not use a music headphones or read while walking
- Stay alert and tuned to your surroundings
- Use body language to communicate that you are calm and confident
- Make quick eye contact with people around you

Trust Your Senses:

- Do not exit your vehicle if you sense trouble
- Leave the area and call police if necessary
- Walk with another customer who appears trustworthy to appear together
- Remember: crimes happen at all times of the day and in all places

If Confronted:

- Remain calm
- Listen to the actor / suspect carefully
- Do nothing more or nothing less than the suspect states
- Do not yell for help as this implies weakness
- Attract attention by yelling: “Get Away”, “Leave Me Alone”, “Get Back”
- We do not recommend getting into a car with a suspect

Many criminals choose their targets (people or businesses) because they appear to be an “Easy” target. If present yourself with a purpose, stand upright, and make eye contact, you may avoid becoming a victim of a crime.

- Pay close attention to your surroundings and trust your instincts.
- If you “sense” a problem, act on your hunch.
- Be prepared to retreat back to your vehicle or back into a building.
- Program you cell phone with important telephone numbers.
- Make sure someone knows your daily schedule.

Disclaimer: The tips provided on these sheets are measures designed to make your residence more secure from unauthorized entry. While there is no guarantee that you will not be the victim of a crime regardless of the precautions taken, by adopting these recommendations you may reduce your risk. The recommendations suggested here have been made in good faith and there is no guarantee, implied or stated, that you will not become the victim of a crime.